

Installation / Installation / Instalación

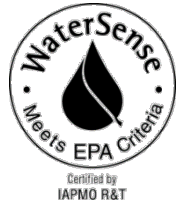

EMBELLISH

5 Hole Roman Tub Trim

Garniture de baignoire romaine à 5 orifices

Piezas exteriores para bañera romana de 5 agujeros



Tools You Will Need / Outils dont vous aurez besoin / Herramientas necesarias



Adjustable Wrench

Clé à molette

Llave ajustable



Pipe Tape

Ruban pour tuyau

Cinta selladora para rosca



Groove Joint Pliers

Pince multiprise

Pinzas ajustables



Phillips Screwdriver

Tournevis cruciforme

Destornillador cruciforme

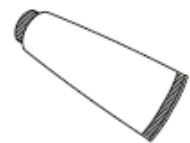

Silicone Sealant

Enduit d'étanchéité au silicone

Sellador de silicona

INSTALLATION TIPS

- The manufacturer suggests using a locally licensed plumber for installation.
- Cover your drain to avoid losing parts.
- This product is engineered to meet the EPA WaterSense flow requirement. The flow rate is governed by the flow controller. If replacement is ever required, be sure to replace it with a WaterSense compliant flow controller to retain the water conserving flow rate of this product.

CONSIGNES DE INSTALLATION

- Le fabricant suggère de confier l'installation à un plombier qualifié pour exercer dans cette région.
- Couvrir le drain pour ne pas perdre des pièces.
- Ce produit est conçu pour respecter les exigences de débit d'eau du programme WaterSense de l'EPA. Le débit est réglé par le régulateur. Si une pièce doit être remplacée, assurez-vous d'utiliser un régulateur de remplacement conforme à WaterSense afin de conserver le taux de débit de ce produit.

CONSEJOS DE INSTALACIÓN

- El fabricante sugiere usar los servicios de un plomero local autorizado para la instalación.
- Tape la boca del desagüe para prevenir la pérdida de piezas pequeñas.
- Este producto está diseñado para cumplir con los requerimientos de flujo de EPA WaterSense. El caudal se rige por el controlador de flujo. Si el reemplazo es necesario, asegúrese de reemplazarlo con un controlador de flujo compatible con WaterSense para retener el caudal de conservación de agua de este producto.



Installation / Installation / Instalación

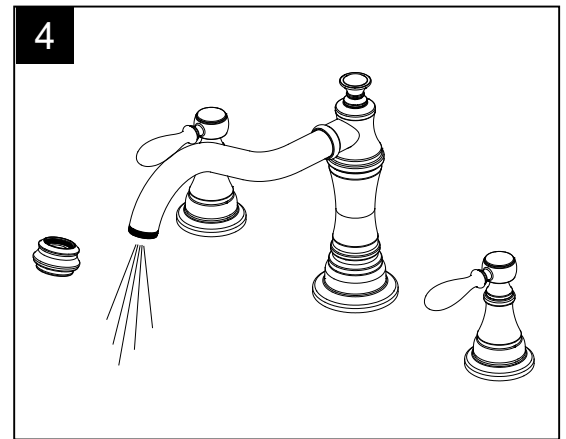
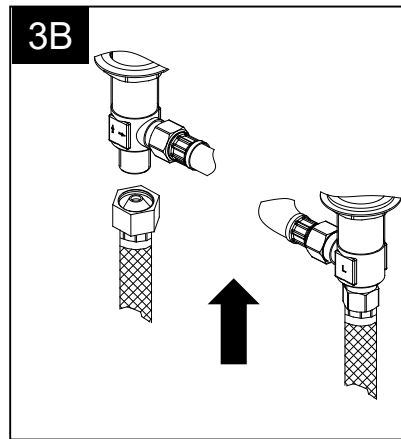
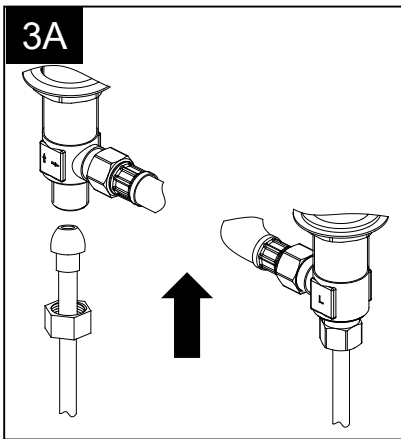
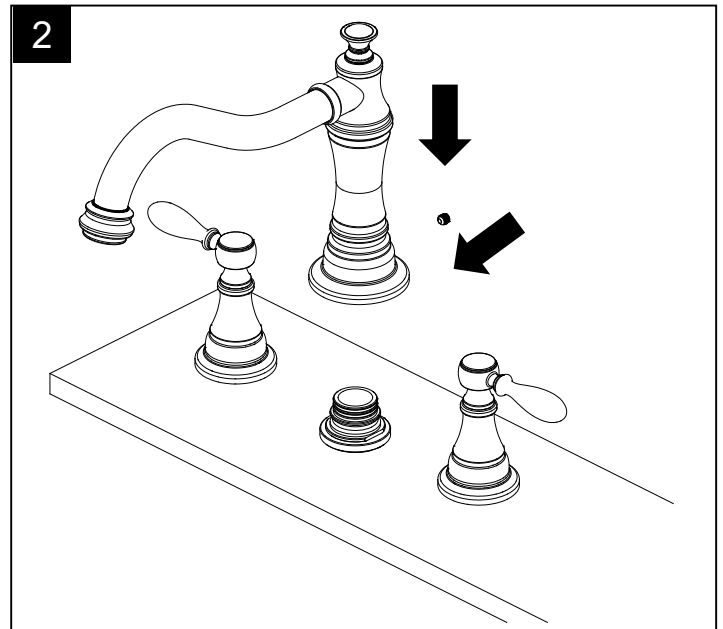
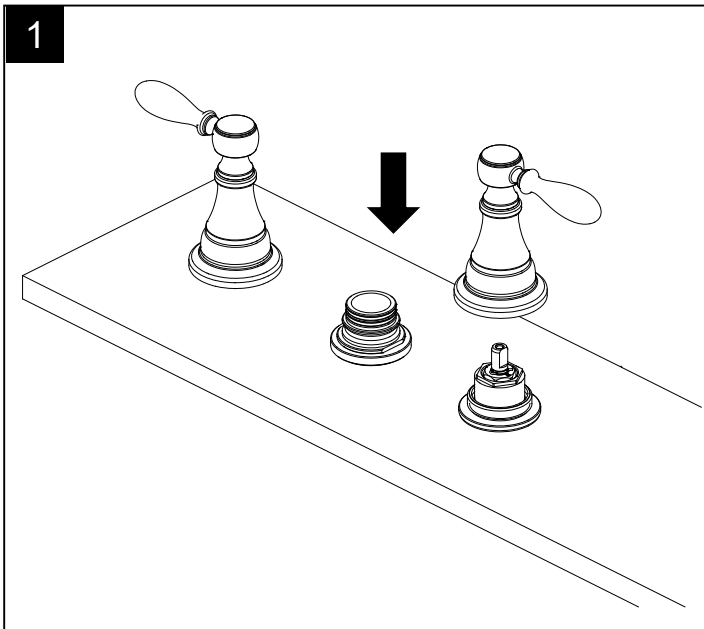

Troubleshooting / Dépannage / Guía de solucionar problemas

If you've followed the instructions carefully and your faucet still does not work properly, take these corrective steps.

Si vous avez suivi attentivement les instructions et que votre robinet ne fonctionne toujours pas correctement, apporter les correctifs suivants.

Si usted ha seguido las instrucciones cuidadosamente y su grifo todavía no funciona correctamente, siga estos pasos correctivos.

Problem / Problème / Problema	Cause / Cause / Causa	Action / Correctif / Solución
Leaks underneath handle.	Retainer nut has come loose. O-ring is dirty or damaged.	Tighten the retainer nut. Clean or replace O-ring.
Fuites sous la poignée.	L'écrou de fixation s'est desserré. Le joint torique est sale ou endommagé.	Serrer l'écrou de fixation. Nettoyer ou remplacer le joint torique.
Goteo debajo de la manija.	La tuerca de ajuste se ha aflojado. La arandela circular está sucia o dañada.	Apriete la tuerca de ajuste. Limpie o reemplace la arandela circular.

Installation / Installation / Instalación

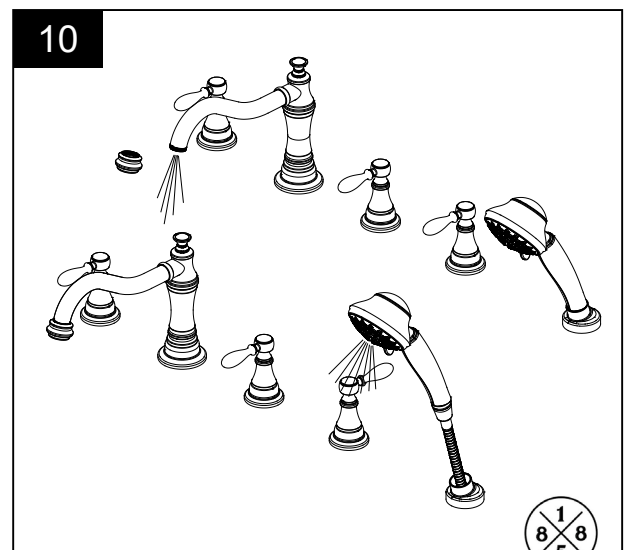
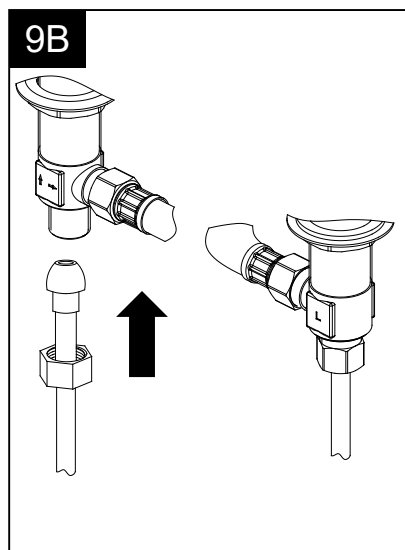
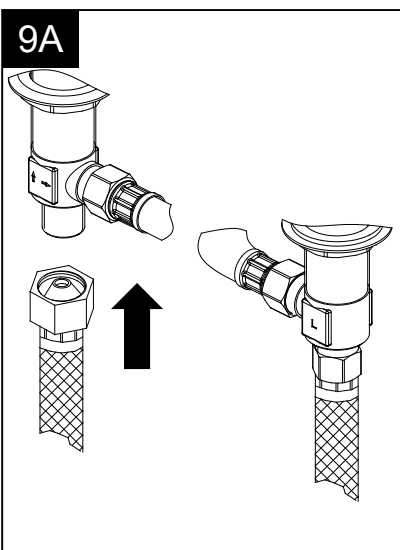
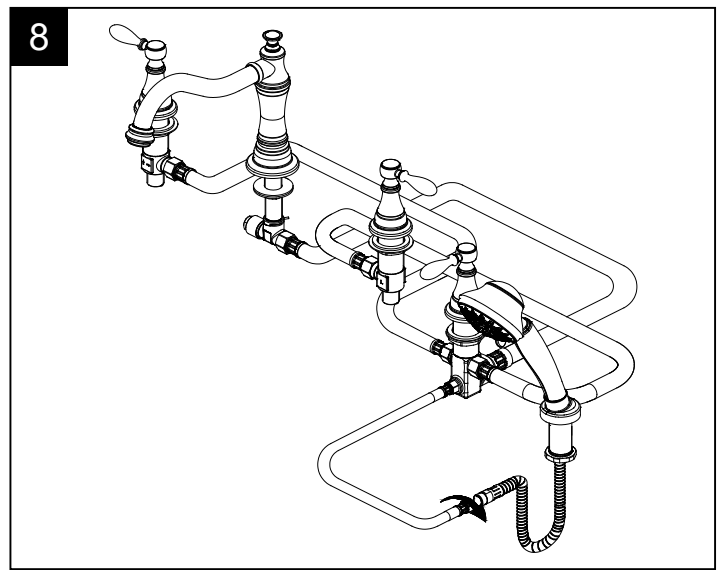
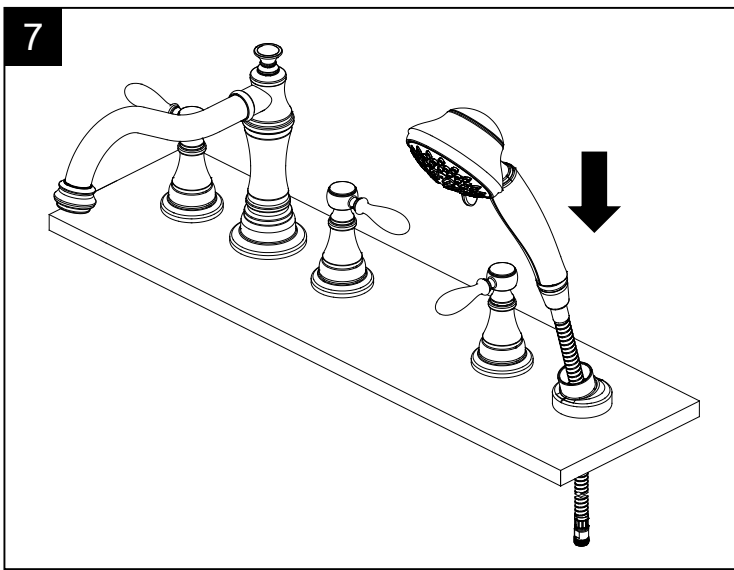
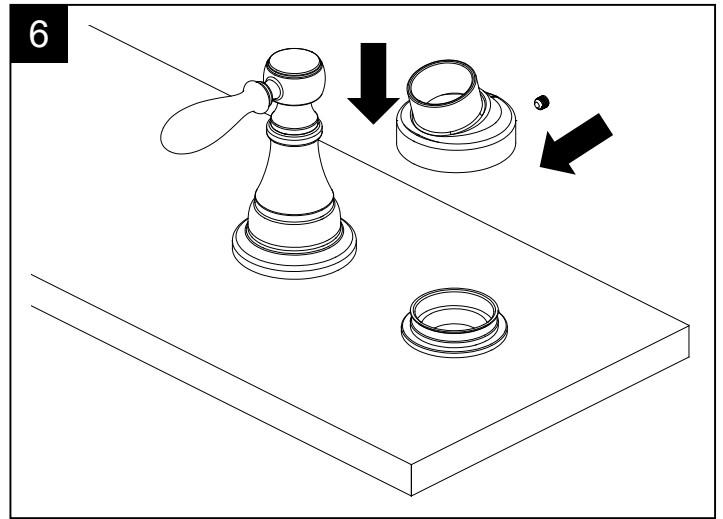
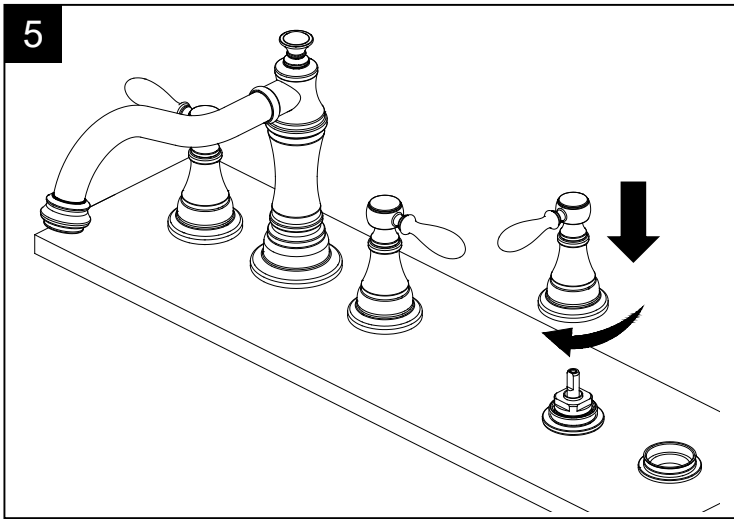

Installation / Installation / Instalación

Replacement Parts / Pièces de rechange / Repuestos

No.	Description	Part No.
1	Aerator / Brise-jet / Aireador	RP30272*
2	Set Screw / Vis de pression / Tornillo de sujeción	RP50054
3	Handle / Poignée / Manija	RP13612*
4	Inverter / Inverseur / Inversor	RP70555

* please indicate finish for these parts

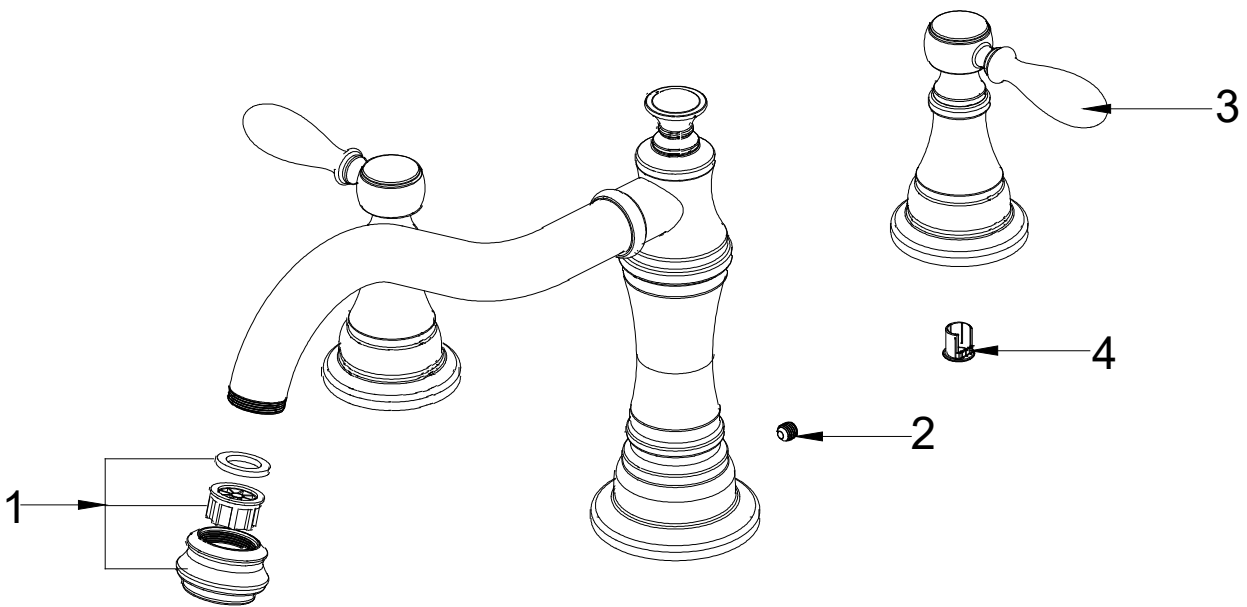

Installation / Installation / Instalación

Replacement Parts / Pièces de rechange / Repuestos

No.	Description	Part No.
1	Handle / Poignée / Manija	RP13612*
2	Inverter / Inverseur / Inversor	RP70555
3	Sprayer / Arroseur / Rociador	RP38395*
4	Set Screw / Vis de pression / Tornillo de sujeción	RP50002
5	Flange / Bride / Brida	RP80658*
6	Hose / Tuyau / Manguera	RP70640
7	Check Valve / Clapet de non-retour / Válvula de control	RP70073

* please indicate finish for these parts

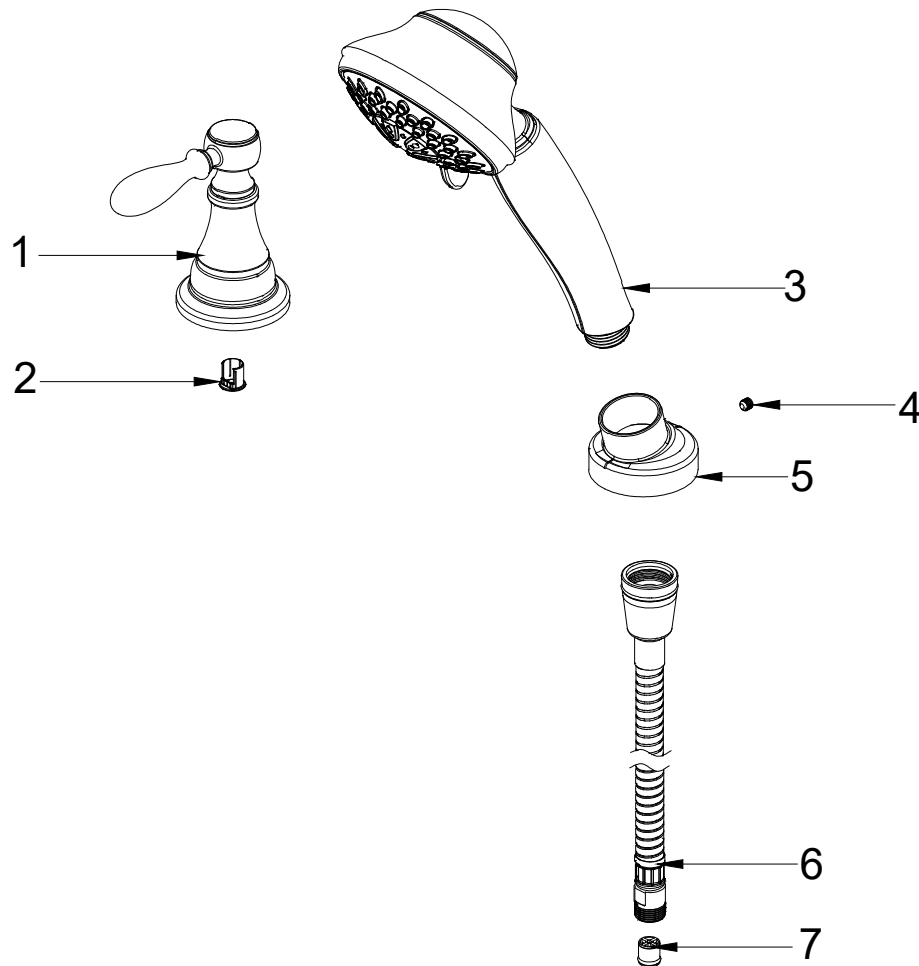

Need Help? Please call our toll-free customer service line at 1-770-205-8792 for additional assistance or service.

Besoin d'aide? Veuillez communiquer avec notre service à la clientèle au numéro gratuit 1-770-205-8792 pour tous renseignements ou services complémentaires.

¿Requiere asistencia? Llame a nuestro Servicio al Cliente, sin costo, al 1-770-205-8792 para asistencia adicional o servicio.

