

Installation / Installation / Instalación



Pull-Down Veggie/Bar Faucet

Robinet de rince-légumes/bar à bec arroseur
Grifo extraíble de para bar/vegetales

Tools You Will Need / Outils dont vous aurez besoin / Herramientas necesarias



Adjustable Wrench

Clé à molette

Llave ajustable



Pipe Tape

Ruban pour tuyau

Cinta selladora para rosca



Groove Joint Pliers

Pince multiprise

Pinzas ajustables



Phillips Screwdriver

Tournevis cruciforme

Destornillador Phillips



Silicone Sealant

Enduit d'étanchéité au silicone

Sellador de silicona

INSTALLATION TIPS

- The manufacturer suggests using a locally licensed plumber for installation.
- Cover your drain to avoid losing parts.
- During installation do not drastically bend, twist or kink supplies or hoses as this may cause low flow or leaks.

CONSIGNES DE INSTALLATION

- Le fabricant suggère de confier l'installation à un plombier qualifié pour exercer dans cette région.
- Couvrir le drain pour ne pas perdre des pièces.
- Pendant l'installation, ne pas plier, tordre ou tortiller les fournitures ou les tuyaux pour ne pas ralentir le débit ou causer des fuites.

CONSEJOS DE INSTALACIÓN

- El fabricante sugiere usar los servicios de un plomero local autorizado para la instalación.
- Tape la boca del desagüe para prevenir la pérdida de piezas pequeñas.
- Durante la instalación, no tuerza, enrolle ni enrosque drásticamente el material ni las mangueras ya que ello podría reducir la circulación del agua o provocar fugas.



Installation / Installation / Instalación

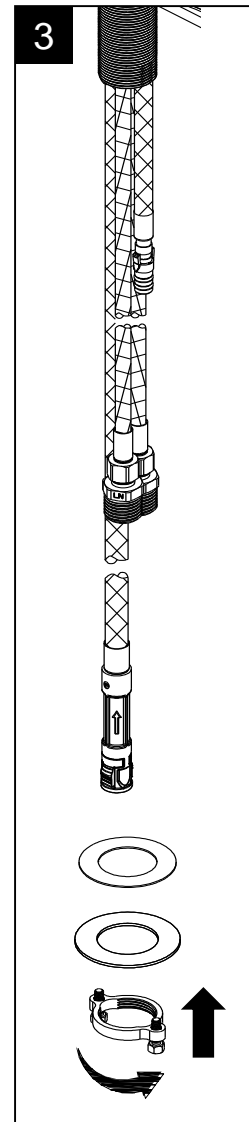
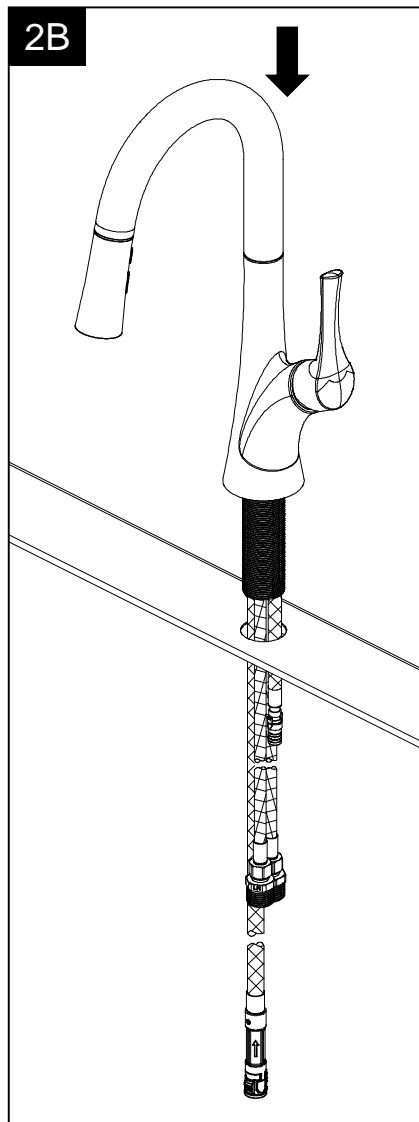
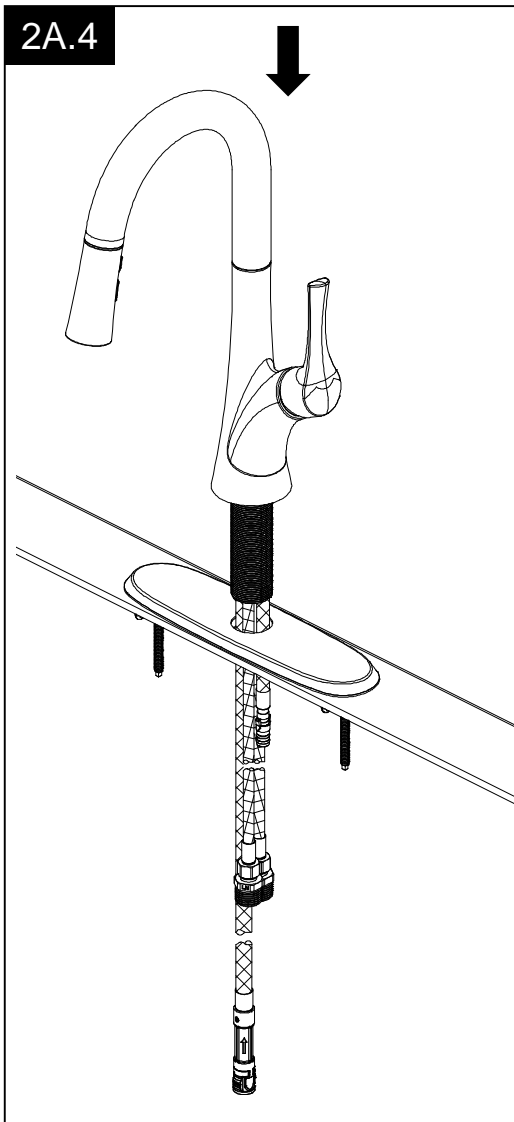
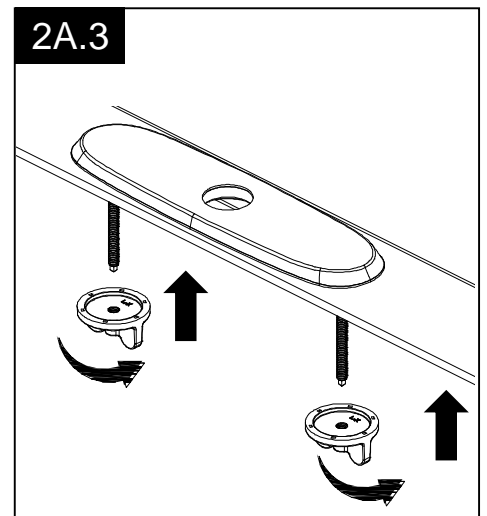
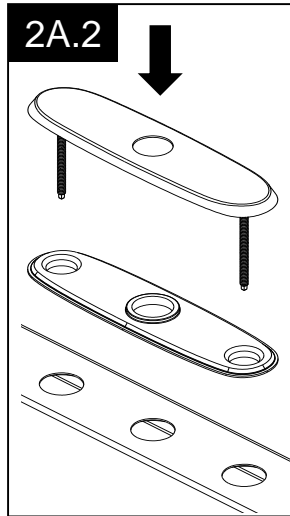
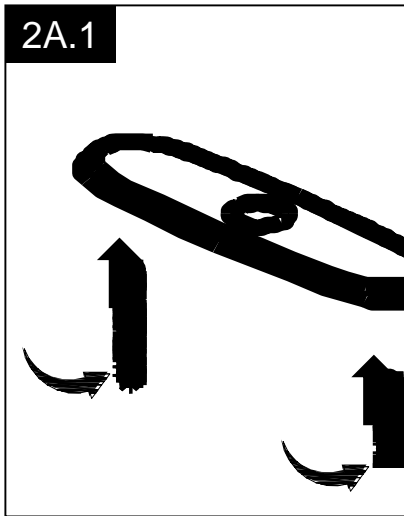
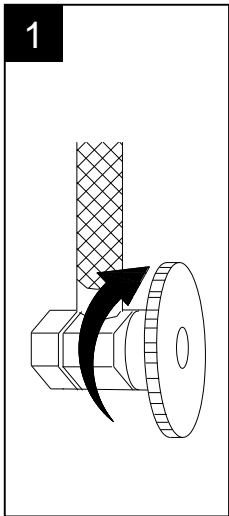

Installation / Installation / Instalación

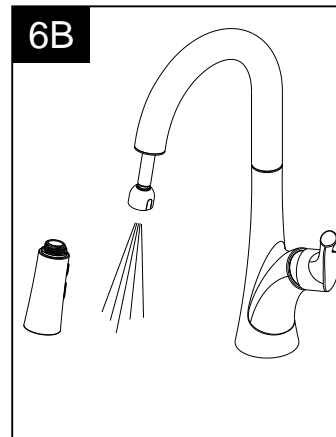
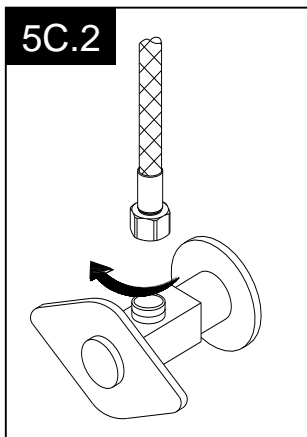
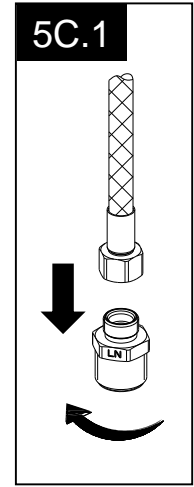
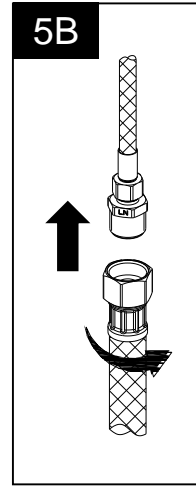
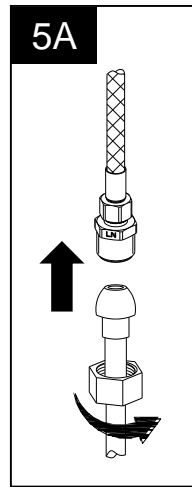
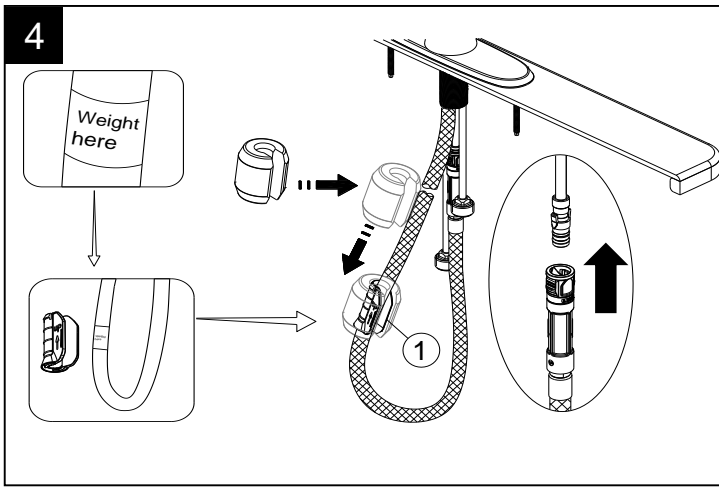

Installation / Installation / Instalación

Troubleshooting / Dépannage / Guía de solucionar problemas

If you've followed the instructions carefully and your faucet still does not work properly, take these corrective steps.

Si vous avez suivi attentivement les instructions et que votre robinet ne fonctionne toujours pas correctement, apporter les correctifs suivants.

Si usted ha seguido las instrucciones cuidadosamente y su grifo todavía no funciona correctamente, siga estos pasos correctivos.

Problem / Problème / Problema	Cause / Cause / Causa	Action / Correctif / Solución
Leaks underneath handle.	Retainer nut has come loose. O-ring is dirty or damaged.	Tighten the retainer nut. Clean or replace O-ring.
Fuites sous la poignée.	L'écrou de fixation s'est desserré. Le joint torique est sale ou endommagé.	Serrer l'écrou de fixation. Nettoyer ou remplacer le joint torique.
Goteo debajo de la manija.	La tuerca de ajuste se ha aflojado. La arandela circular está sucia o dañada.	Apriete la tuerca de ajuste. Limpie o reemplace la arandela circular.
Aerator leaks or has an inconsistent water flow pattern.	Aerator is dirty or misfitted.	Unscrew aerator, remove any debris, check seating of rubber seal then re-assemble aerator.
Le brise-jet fuit ou la diffusion des jets n'est pas uniforme.	Le brise-jet est sale ou mal ajusté.	Dévisser le brise-jet, le nettoyer, vérifier l'assise du joint en caoutchouc et remettre le brise-jet en place.
El aireador gotea o el chorro de agua está irregular.	El aireador está sucio o mal puesto.	Destornille el aireador, límpielo, revise el asiento del empaque de goma, y vuelva a ensamblar el aireador.



Installation / Installation / Instalación

Replacement Parts / Pièces de rechange / Repuestos

No.	Description	Part No.
1	Sprayer / Arroseur / Rociador	RP38464*
2	Inverter / Inverseur / Inversor	RP64259
3	O-Ring / Joint torique / Empaque circular	RP60006
4	Wearable Ring / Rondelle d'usure / Anillo plástico	RP64092
5	Cartridge / Cartouche / Cartucho	RP20090
6	Nut / Écrou / Tuerca	RP70261
7	Cap / Capuchon / Cubierta circular	RP80184*
8	Screw / Vis / Tornillo	RP50200
9	Handle / Poignée / Manija	RP13253*
10	Set Screw / Vis de pression / Tornillo de sujeción	RP50002
11	Escutcheon / Applique / Placa decorativa	RP80246*
12	Base Plate / Plaque de base / Placa de base	RP80356
13	Bolt / Boulon / Perno	RP50071
14	Nut / Écrou / Tuerca	RP56036
15	Block / Bloc / Bloque	RP70421
16	O-Ring / Joint torique / Empaque circular	RP60002
17	Coupling Nut / Écrou de raccordement / Tuerca de unión	RP56002
18	Washer / Rondelle / Arandela	RP64131
19	Metal Washer / Rondelle de métal / Arandela de metal	RP64146
20	Nut / Écrou / Tuerca	RP56077
21	Screw / Vis / Tornillo	RP50004
22	Weight clip / Pince lestée / Sujetador con peso	RP70590
23	Weights / Poids / Pesas	RP70689
24	O-Ring / Joint torique / Empaque circular	RP60089
25	Quick Connector / Raccord rapide / Conector rápido	RP70429

* please indicate finish for these parts

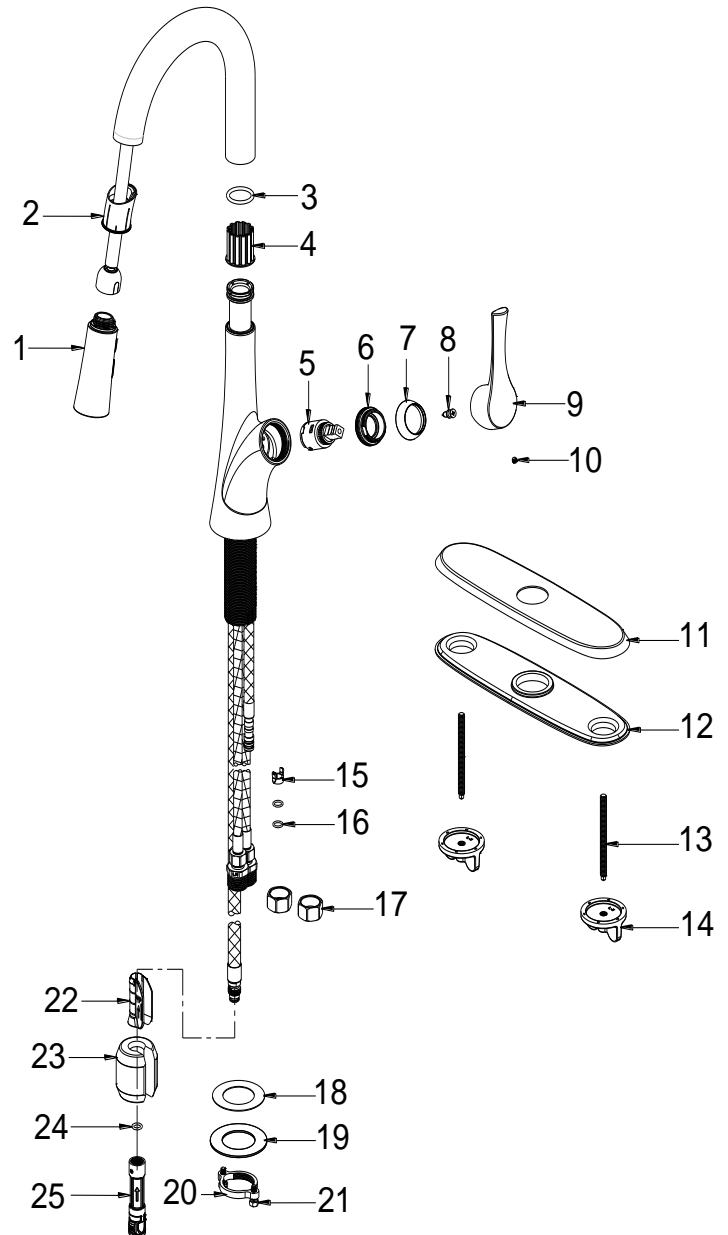

Need Help? Please email CustomerService@1858Brands.com for additional assistance or service.

Besoin d'aide? Veuillez envoyer un e-mail à CustomerService@1858Brands.com pour obtenir une assistance ou un service supplémentaire.

¿Requiere asistencia? Envíe un correo electrónico a CustomerService@1858Brands.com para obtener asistencia o servicio adicional.

